

evolution  fires[®]

ADVANCE SERIES

ADVANCE SERIES 1300

ADVANCE SERIES 1500

ADVANCE SERIES 1800

ADVANCE SERIES 2000



HOW TO BUILD A MEDIA WALL FEATURING THE ADVANCE SERIES SCAN THE QR CODE



TABLE OF CONTENT

Important safety information!	03
Parts and hardware	04
Specification and dimension	04
Preparation	05
Installation - minimum clearances	06
Installation overview	07
Operation	08
Unpacking	09
Installation choose your viewing style	10
Optional side panels	11
Product information	12
Installation and location	13
Operating the fire	15
Wi-fi / smart control	18
Cleaning and maintenance	25
Troubleshooting/ faq	27

IMPORTANT SAFETY INFORMATION!

WARNING

When using electrical appliances basic precautions should always be followed to reduce the risk of fire, electric shock and injury to persons, including the following:

READ ALL THE INSTRUCTIONS BEFORE USING THIS APPLIANCE

- ✔ This heater is hot when in use. To avoid burning, do not touch hot surface. If provided, use handles when moving this heater. Keep combustible materials, such as furniture, pillows, bedding, papers, clothes, and curtains at least 1 m from the front of the heater and keep them away from the sides and rear. In order to avoid overheating, do not cover the heater.
- ✔ Extreme caution is necessary when any heater is used near children or the infirm and whenever the heater is left operating and unattended.
- ✔ Always unplug heater when not in use.
- ✔ Do not operate any heater with a damaged cord or plug or after the heater malfunctions, has been dropped damaged in any manner, return heater to authorized service facility for examination, electrical or mechanical adjustment, or repair.
- ✔ Indoor use only, do not use outdoors.
- ✔ This heater is not intended for use in bathrooms, laundry areas and similar indoor locations. Never locate heater where it may fall into a bathtub or other water containers.
- ✔ Do not run cord under carpeting. Do not cover cord with throw rugs, runners, or similar coverings. Arrange cord away from traffic area and where it will not be tipped over.
- ✔ To disconnect heater, turn controls to off, then remove plug from outlet.
- ✔ Do not inset or allow foreign objects to enter any ventilation or exhaust opening as this may cause an electric shock or fire or damage the heater.
- ✔ To prevent a possible fire, do not block air intakes or exhaust in any manner. Do not use on soft surfaces, like a bed, where openings may become blocked.
- ✔ A heater has hot and arcing or sparking parts inside. Do not use it in areas where gasoline, or flammable liquids are used or stored.
- ✔ Use this heater only as describes in this manual. Any other use not recommended by the manufacturer may cause fire, electric shock, or injury to persons.
- ✔ DANGER-High Temperatures may be generated under certain abnormal conditions. Do not partially or fully cover or obstruct the front of this heater.
- ✔ Replacement of the lamps should be done only while the heater is disconnected from the supply circuit.
- ✔ This appliance is not intended for use by persons (including children) with reduced physical, sensory or capabilities, or lack of experience and knowledge, unless they have been given supervision or instruction concerning use of the appliance by a person responsible for their safety. Children should be supervised to ensure that they do not play with the appliance.
- ✔ CAUTION: In order to avoid a hazard due to inadvertent resetting of the thermal cut-out, this appliance must not be supplied through an external switching device, such as a timer, or connected to a circuit that is regularly switched on and off by the utility.
- ✔ Electric sockets in residential rooms should comply with the 6/12 spacing requirements, this comes from the NEC and states that in a living area of a home, you must keep an electrical socket (outlet) 6 feet from any obstruction, or break in the wall, such as a doorway and no more than 12 feet from the previous electrical socket.
- ✔ Whilst electric fires are very safe, we recommend you only plug into a mains socket, do not use an extension lead as the extension lead wire can get knocked, or overheat and become a hazard. You should never overload an extension lead or multiple extension leads.

✔ **DO NOT REMOVE THE PLUG FROM THE APPLIANCE THIS WILL CANCEL YOUR WARRANTY**

PARTS AND HARDWARE

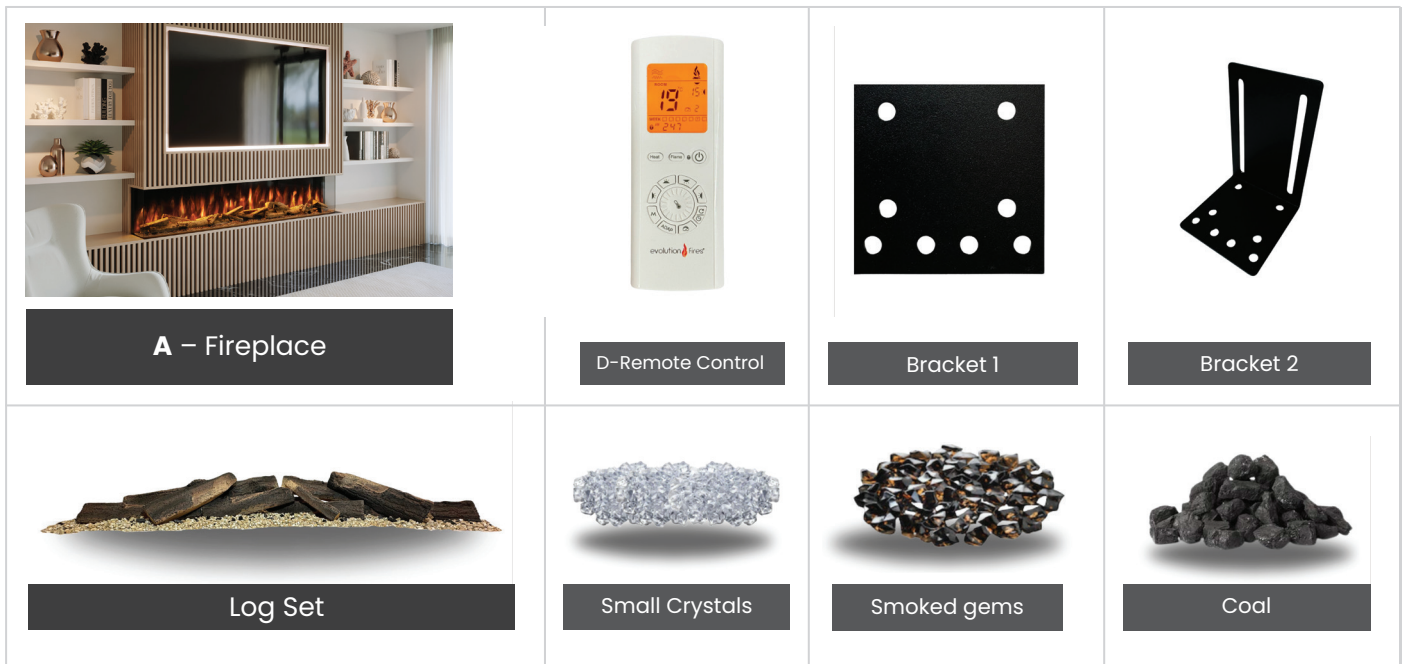

SPECIFICATION AND DIMENSION

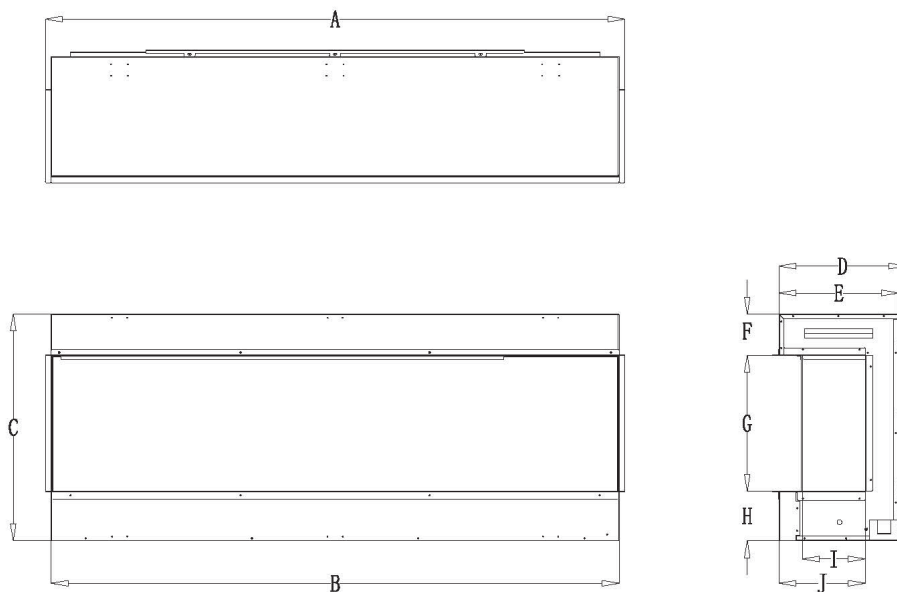

Dimensions

	A	B	C	D	E	F	G	H	I	J
EASI300	1333	1302	600	335	316	109	360	131	167	228
EASI500	1533	1502	600	335	316	109	360	131	167	228
EASI800	1833	1802	009	335	316	109	360	131	167	228
EAS2000	2033	2002	600	335	316	109	360	131	167	228

PREPARATION



This product includes a GLASS panel! Always use extreme caution when handling glass. Failure to do so could result in personal injury or property damage.

WARNING REMOVAL OF THE PLUG TOP WILL INVALIDATE YOUR WARRANTY

Check the parts list to make sure nothing is missing. Dispose of packaging materials properly. Please recycle whenever possible.

You will need the following tools (not included): Phillips screwdriver; stud finder; level; tape measure; electric drill.

MINIMUM CLEARANCE TO COMBUSTIBLES

Select a suitable location that is not susceptible to moisture and is away from drapes, curtains, furniture and high traffic areas.

Due to the many different materials used on media wall builds, it is highly recommended that you consult your local builder before you install this appliance on the wall.

Note:

It is strongly recommended that all electrical sockets are installed behind the TV to ensure the plug attached to the fire is easy accessible.

Electrical installation work must be carried out only by people who have the knowledge, skill and experience needed to avoid any danger to themselves and others.

We strongly recommend that you use a registered electrician to do any electrical installation work you need.

They work to the UK national safety standard and will give you a safety certificate to confirm that their work has been designed, inspected and tested in line with that standard.

- A** Select a location that is not prone to moisture and is located at least 36 inches (914) away from combustible material.
- B** Do not cut the plug off the power cable, this also applies to fuse spares. If the plug is removed Evolution Fires will no longer honor the warranty.
- C** The frame of the media wall must be hollow allowing air flow to reach the fire. If there is not enough airflow getting to the fire you will find your fire switches off when the heater is used. This is happening because the fire is overheating and needs to cool down before switching back on. **Continued use will cause unrepairable damage to your appliance.**
- D** Check the fire is working before installing

INSTALLATION – MINIMUM CLEARANCES

Your appliance is a recessed and/or mantel installed appliance. Select a suitable location that is not susceptible to moisture build-up. It must be located with enough distance away from flammable materials such as curtains, furniture and high traffic areas.

Note

Follow all local and national electrical regulations/codes.

Note

the vents on the fire unit are not obstructed and the frame is hollow to allow for air-flow.

Note

We recommend you don't place soft furnishings directly in front of the heater outlet.



Please check the product works before installation as we will not accept responsibility for faults once the product has been installed.

MEDIA WALL BUILD MINIMUM CLEARANCES (MM)

Bottom	0mm
Sides	0mm
Back	30mm
Top	0mm
Front (Measured from glass, plasterboard is exempt)	200mm

INSTALLATION OVERVIEW

Your appliance allows for three installation configurations.



One Sided

Glass exposed on the front only.



Two Sided

Glass exposed on front and one side.



Three Sided

Glass exposed on the front, left and right sides.

OPERATION



Please read the entire owner's manual, including all safety information, before plugging in or using this product. Failure to do so could result in fire, electric shock, or serious personal injury.

Power

Plug the power cord into a 220-240V 50Hz outlet (see **IMPORTANT SAFETY INFORMATION** on **Pages 2 and 3**). Make sure the outlet is in good condition and the plug is not loose. **NEVER** exceed the maximum amperage for the circuit. **DO NOT** plug other appliances into the same circuit.

Air Flow Vents

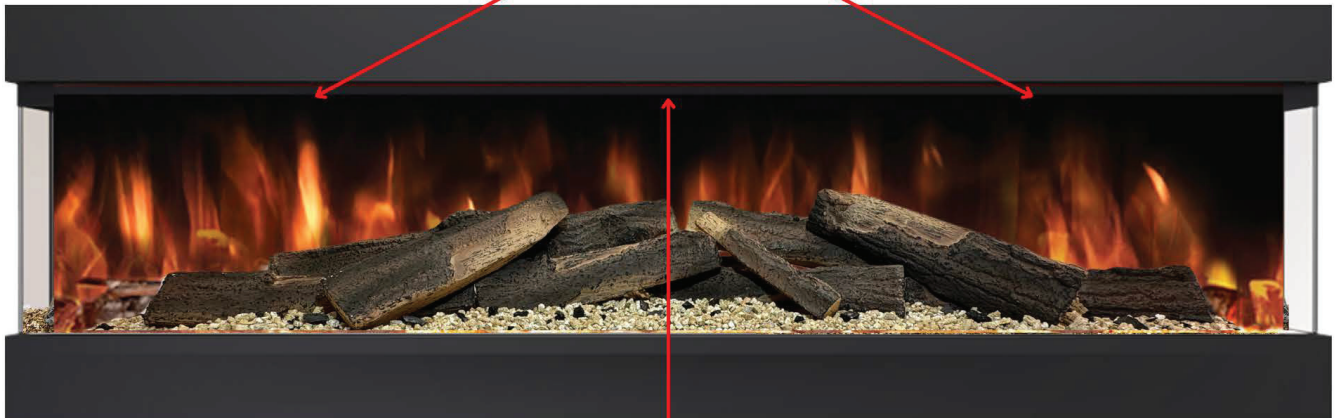

Heater

UNPACKING

Congratulations on your new electric fire. In order to unpack your product without causing any damage to yourself or the product, please take care and follow the instructions.

- 1 Place the box on a flat surface. Make sure you have enough space.
- 2 Remove any rings or bracelets which may scratch the product or be damaged during removal.
- 3 Carefully remove the appliance from the box and put all packing aside.
- 4 Please keep the original packing for further storage or transportation.
- 5 Prior to installation, test the product to check that the appliance is functioning correctly.

KEEP PLASTIC BAGS AWAY FROM CHILDREN AND ANIMALS

Use this product **ONLY** as described in this instruction manual. Any other use is discouraged in order to prevent bodily harm and/or fire.

FRONT GLASS

Remove clamp from top of glass panel by undoing 2 screws.

Carefully tilt glass panel forward so top edges are clear of chassis and slide upwards enough to clear location at the bottom of the fire. Place glass panel in a safe place to avoid breakage.

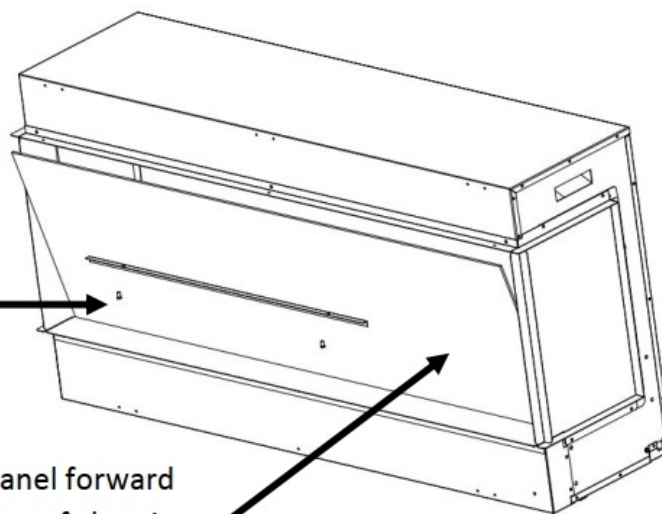

Glass sucker clamp should be used to reinstall the glass panel once the logs have been arranged



INSTALLATION CHOOSE YOUR VIEWING STYLE

Attach the relevant side panels or side trims to achieve your look.

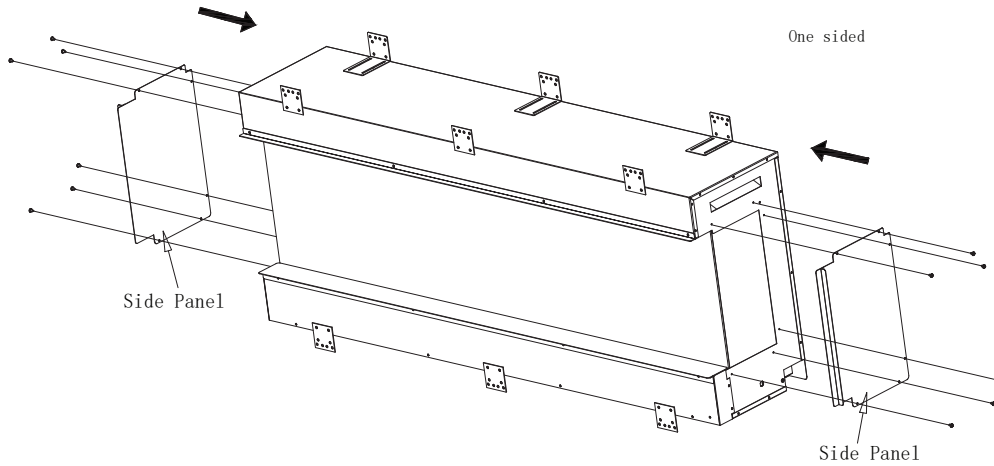

One sided

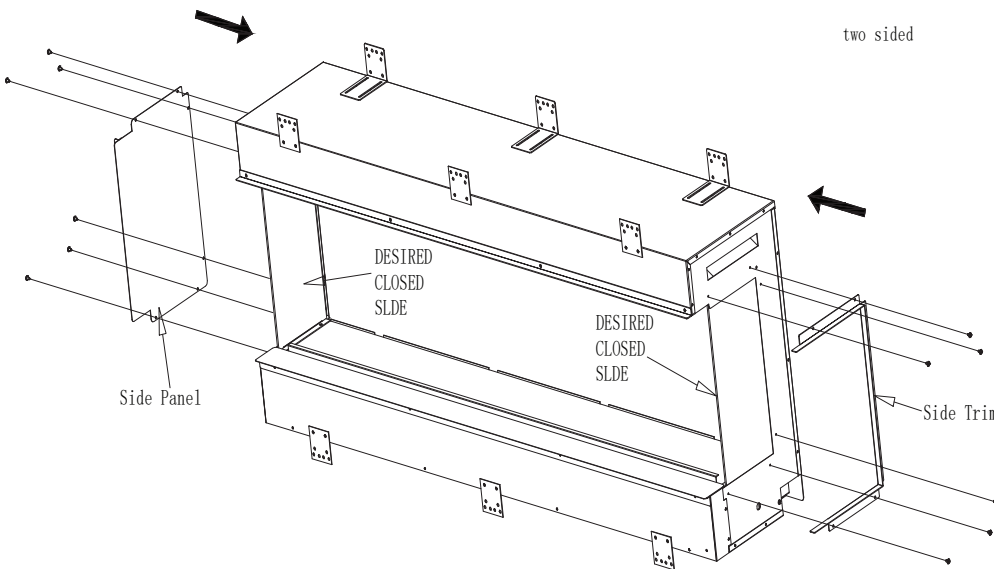

Two sided

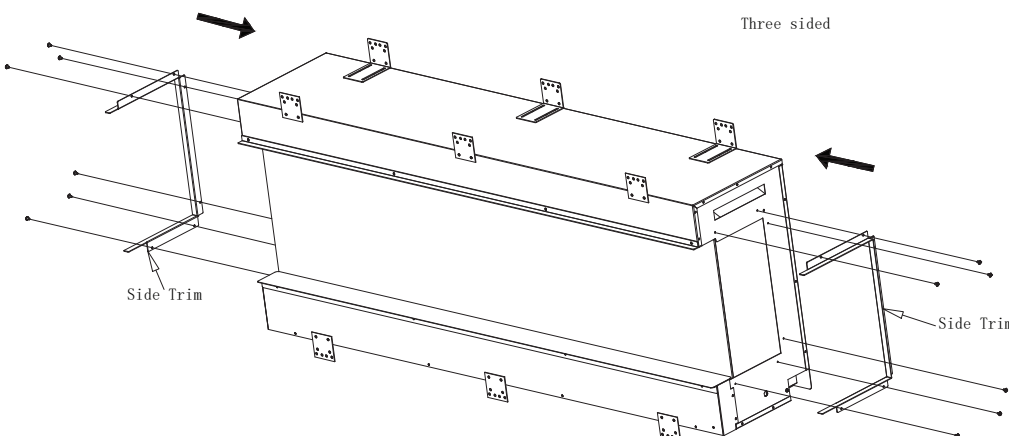

Three sided

OPTIONAL SIDE PANELS

When unpacked the fire has only one pane of glass visible at the front. The two side sections are covered by blanking plates.

If the fire is to be installed as a two or three sided appliance these plates need to be removed. To do this unscrew the fire frame from the body of the fire, remove the panel and then refit the fire frame.

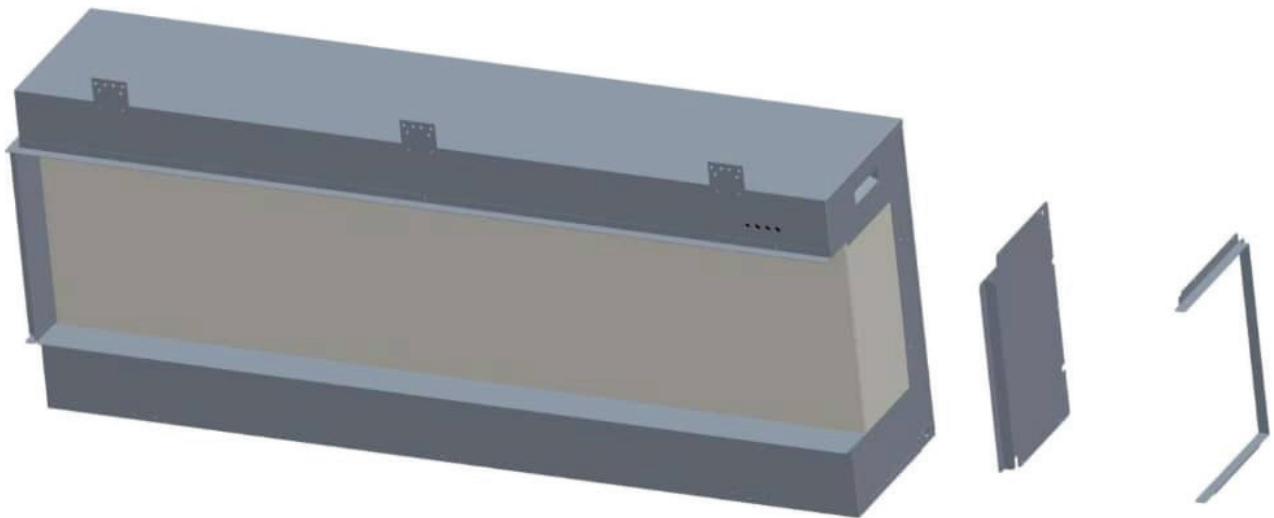

Multi Sided Installation

One Sided

Glass exposed on the front.



Two Sided

Glass exposed on the front and left or right sides.



Three Sided

Glass exposed on all sides.

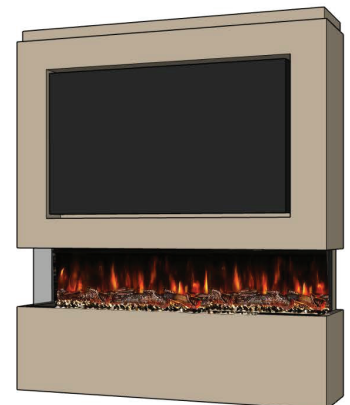

PRODUCT INFORMATION

Product technical information :

Supplier name	Evolution Fires
Model number	EAS1300 EAS1500 EAS1800 EAS2000
Voltage	220-240V AC 50HZ
Fuse	13Amp
Nominal heat output	2.0KW
Minimum heat output	1.0KW
Maximum heat output	2.0KW

PRODUCT DIMENTIONS

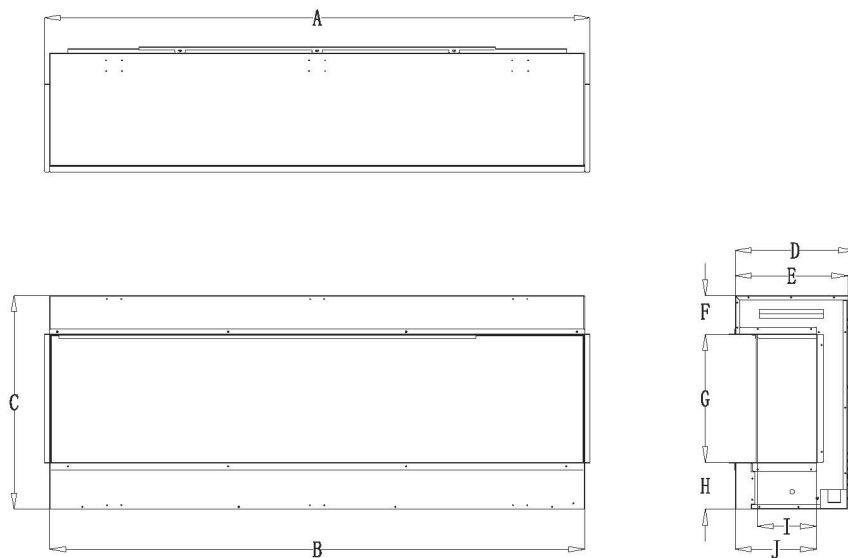

Dimensions										
	A	B	C	D	E	F	G	H	I	J
EAS1300	1333	1302	600	335	316	109	360	131	167	228
EAS1500	1533	1502	600	335	316	109	360	131	167	228
EAS1800	1833	1802	600	335	316	109	360	131	167	228
EAS2000	2033	2002	600	335	316	109	360	131	167	228

INSTALLATION AND LOCATION

Please read the instructions carefully **BEFORE** installation. The installation **MUST** be carried out by a qualified person.

Connect the appliance to a single-phase AC supply of the voltage specified on the ratings plate.

In the instance that the fire is connected directly to the mains electricity supply, a fused switched spur with a 13 amp fuse must be fitted.

- ✓ The power supply must be able to handle 2000 watts (2kw).
- ✓ This appliance must be earthed
- ✓ Do not use an extension lead or a timer.

Always ensure that all electrical work complies with the relevant building regulations and the electrical code of practice.

This product is designed to be either wall mounted and / or fitted and fixed inside a frame. This appliance has multiple electrical components that must be kept away from water and damp or moist conditions.

This product should be fitted using one of the following options:

- 1 Wall Mounted** - Using the H bracket which is located on the back of the appliance. It is important to use fixtures that are appropriate for the type of wall. The wall must be of sound construction and able to hold the weight of the appliance.
- 2 Mounted on a solid base** - Please keep a distance of at least 5 cm from any non-combustible materials.
- 3 Fitted into a Studded Wall** - Which needs to be finished with either plasterboard or a plastered finish. The fire can then be installed with the facing trim of the fire flush up to the plastered finish. See Drawings below:

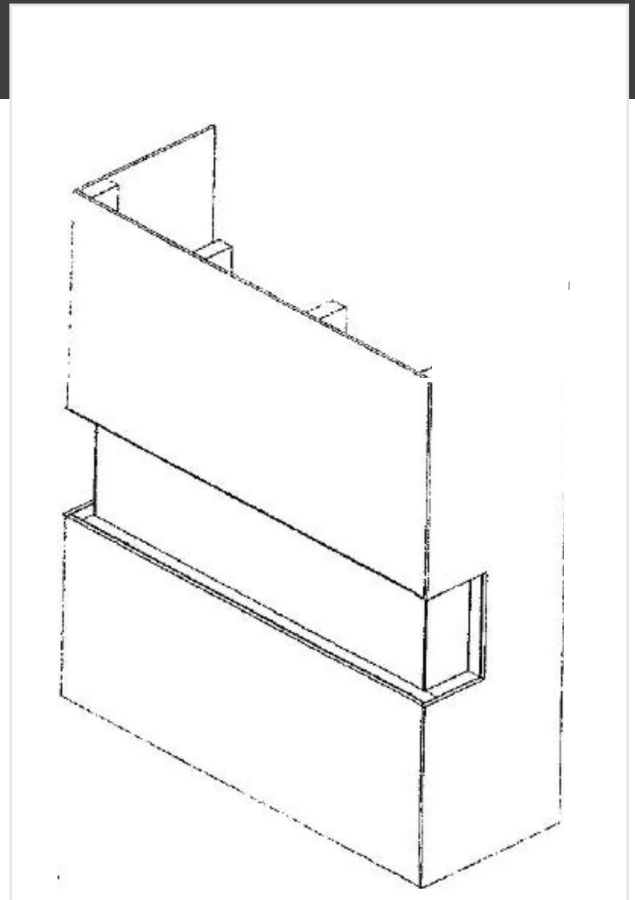
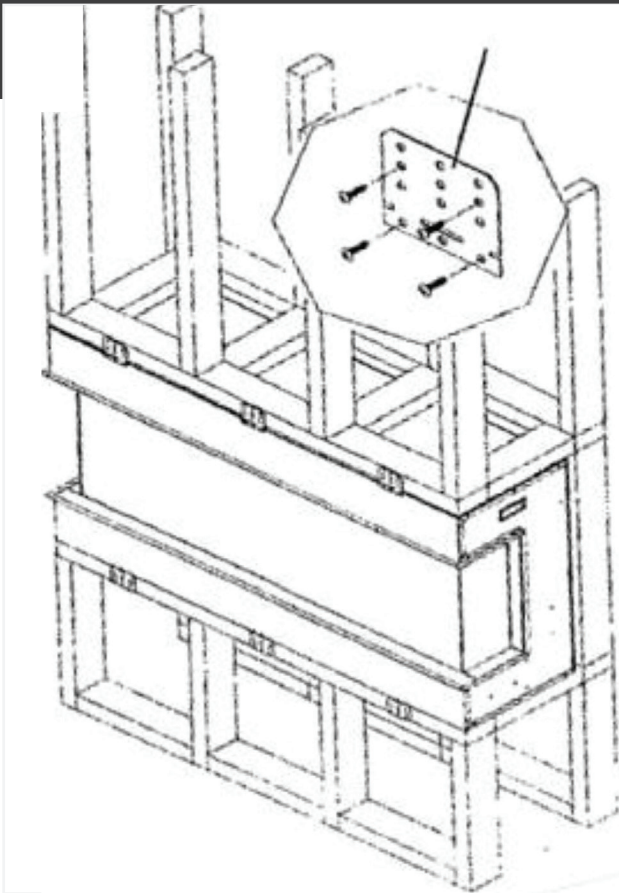

Make sure that the cable is not run across the heater and can be plugged into the mains socket without the use of an extension cable.

Please make sure that the plug socket outlet is in a location that is easily accessible. The appliance should be switched off when not in use and for maintenance.

Crystal Fuel Bed

The accessory box which is packed inside the fire contains the mixed black and white nuggets that create the fire bed. These should be placed on the base of the fire in a random manner.

Log Fuel Bed

Scatter the vermiculite on the base, place the coals on top of the vermiculite. The logs are then placed in a position of your choice on top of these. The logs are delicate and should be handled with care.

OPERATING THE FIRE

Manual control:

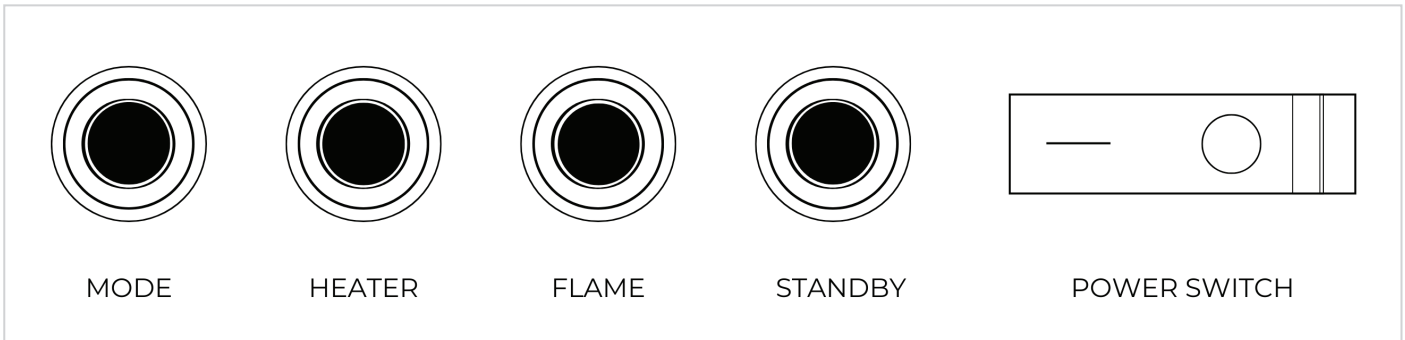

This appliance can be operated manually using the controls situated on the top right hand side of the fire screen.

ON/OFF POWER SWITCH- This switch is used to turn the mains supply to the appliance on or off. When the switch is in the ON position an orange indicator light will show in the middle of the screen. This needs to be in the on position for both manual and remote operation.

STANDBY- Used to switch the appliance ON or OFF into standby mode. **FLAME-** Pressing this button will cycle through the four different flame brightness levels.

HEATER- Use this button to select low heat, high heat or heater off.

When low heat is selected the indicator light will glow orange.

When high heat is selected the indicator light will glow red.

Please note that the heater will only operate when the room temperature is below the temperature on the handset, which can be adjusted using the remote or through the app. When the heater switches off the fan will continue to run to cool the appliance.

MODE- Shuffle through a selection of pre-programmed effects.

Remote control:

Ensure that the ON/ OFF Power Switch on the fire is in the ON position.

Point the remote-control handset directly towards the fire and press the appropriate button to operate the fire.

Standby button:

Use this button to switch the fire on / off, and unlock the remote if remote is locked.

Heat button:

Use this button to control heating level.

Setting the colour functions:

Press lamp buttons: 

Then rotate the rotate button, will change colour of flame light, bottom light and top light separately.

Advance Remote Functions

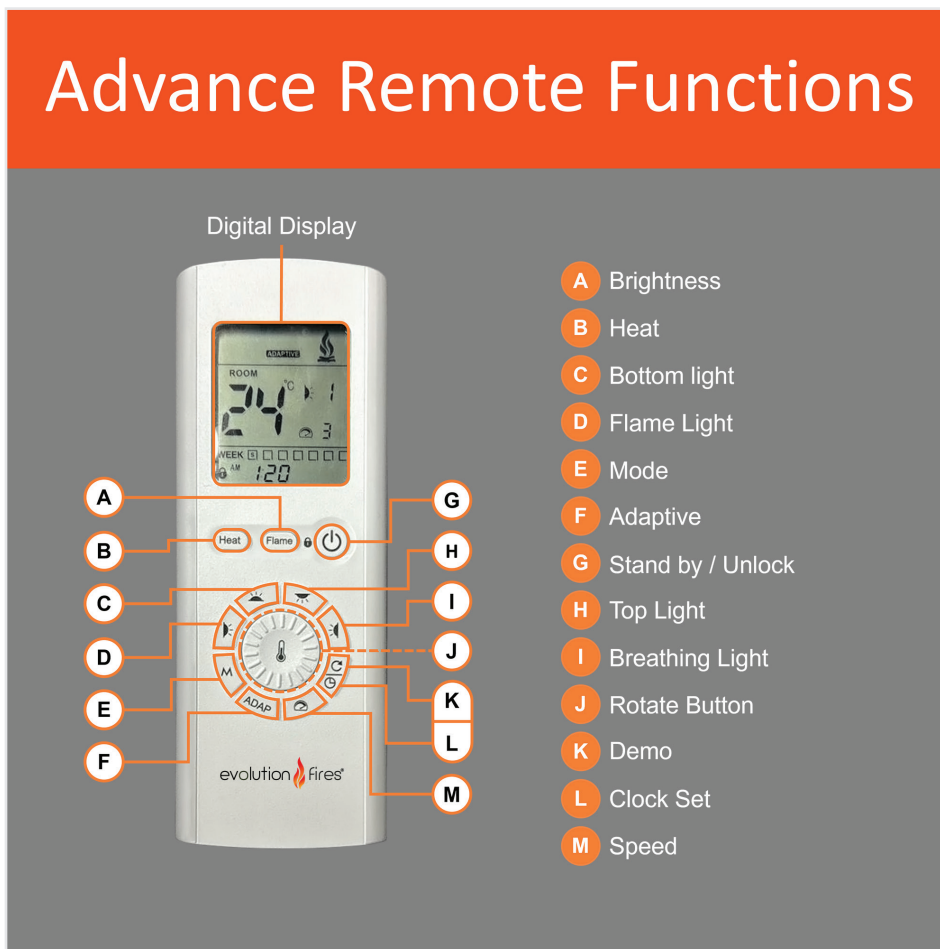

Setting the Time:

- 1 Press clock set button to start clock set.
- 2 Use rotate button to select days, hours, minutes, and confirm setting.

Set Mode and Speed:

Press Mode or Speed button, then use rotate button to set, will see number indicator on remote screen.

Adjusting the desired temperature :

While the fire is heating on, use rotate button to set the desired temperature.

A confirmation beep will be heard from the fire. If the room is already warmer than the temperature set then the heater will switch off until the thermostatic sensor detects a fall in temperature.

Adaptive Control

Adaptive control works in target temperature 25°C with high heat.

Breathing and Demo Control

Press breathing light button or Demo button will switch the function on / off.

WI-FI / SMART CONTROL

Preparation

In order to prepare please check that your mobile phone is connected to your Wi-Fi router. Plug your fire in to the wall. Switch the fire on at the wall socket. **DO NOT** use the **STANDBY** button to turn on, use the power switch. You should see an orange dot appear on the screen.

The buttons on the fire are as follows:

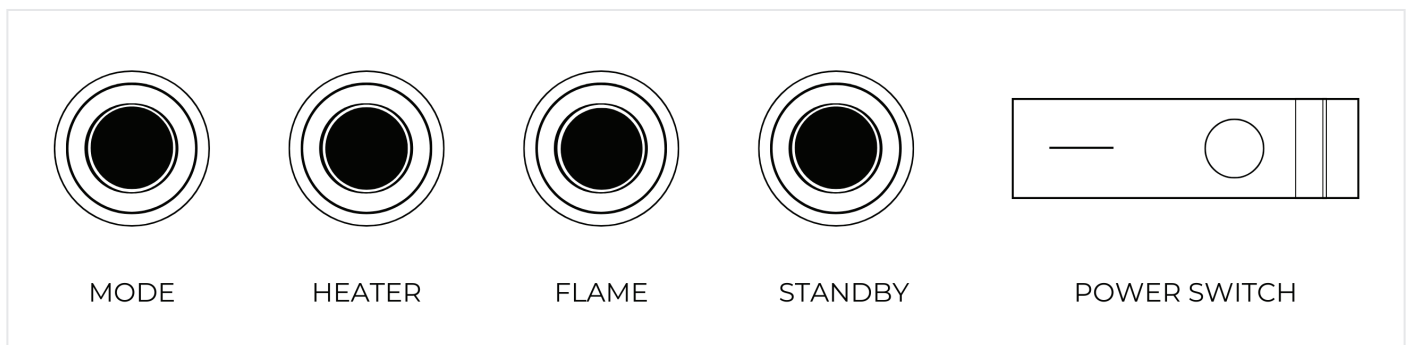

1. Download the 'Smart Life' APP

- ✓ The app is free on both Google play and the app store.
- ✓ Please search 'Smart Life - Smart Living'.
- ✓ Download the app.

2. Open the Smart Life App, Register and Log in

- ✓ Open the app and click the register button, unless you have an existing
- ✓ account, then please log in with your existing details.
- ✓ Input an email, the app will send a code in order to verify your email.
- ✓ Once you have received the code, input the code and create your password.

USE THIS YOUTUBE LINK FOR GUIDANCETO CONNECT TO WIFI

<https://youtube.com/shorts/sP1biXZDXng>

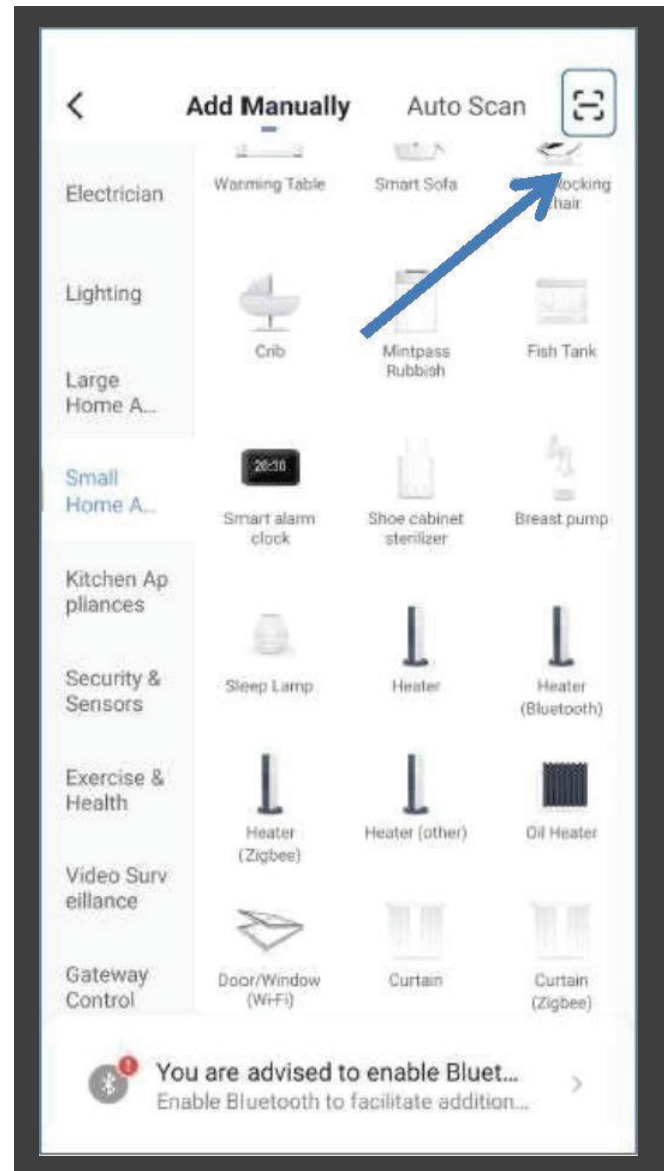
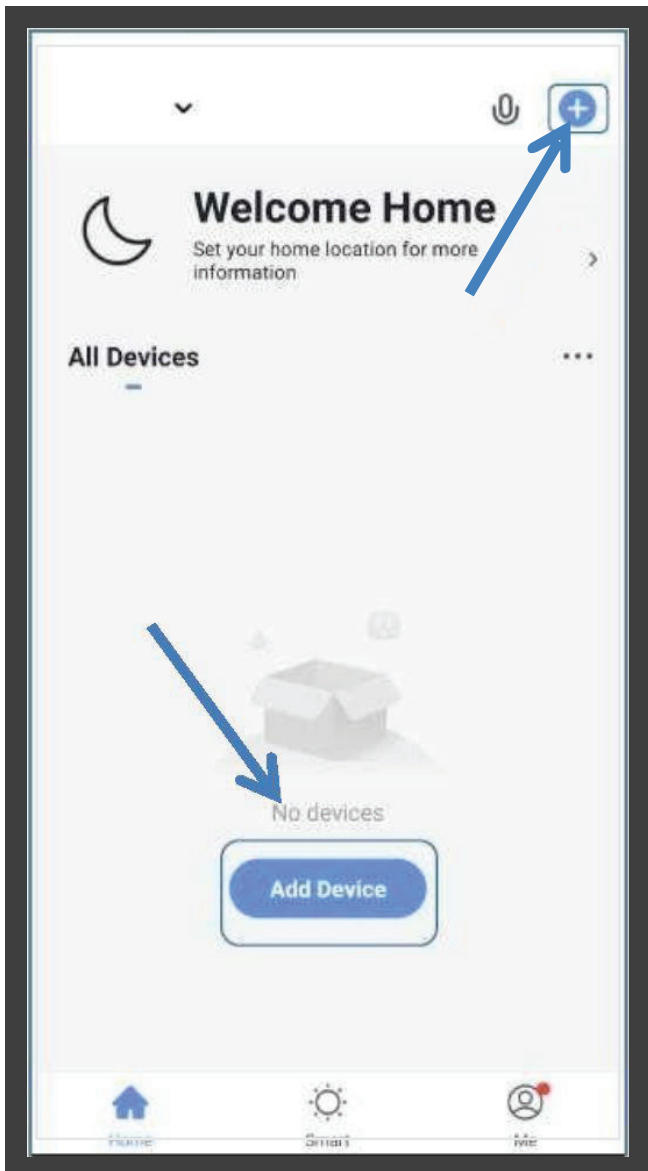

3. Add your device

- ✔ Please touch the 'Add device' button or the 'Add' symbol to add your device.

4. Scan the QR code

- ✔ Touch the 'SCAN' symbol. Scan the below QR code.



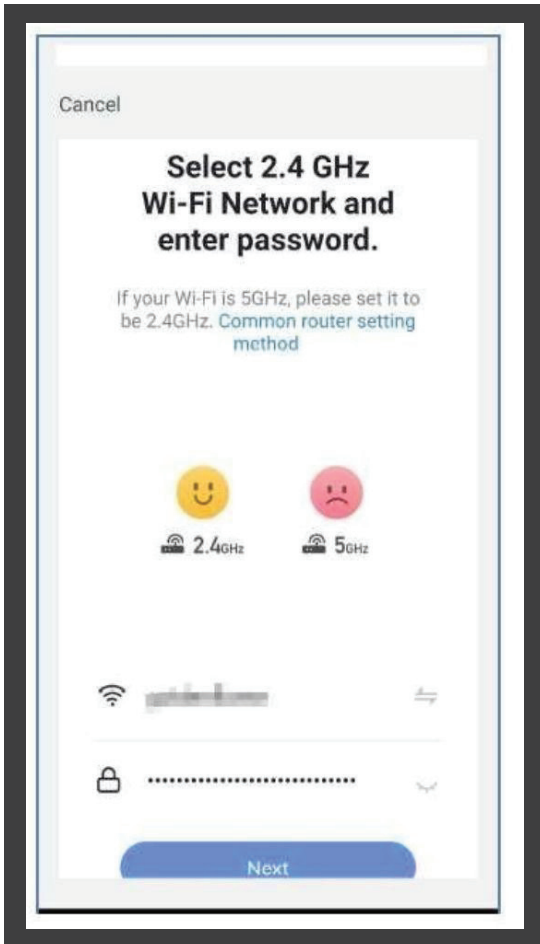

5. Connecting to your Wi-Fi

- ✔ Select your Wi-Fi network and input the password of your Wi-Fi network.

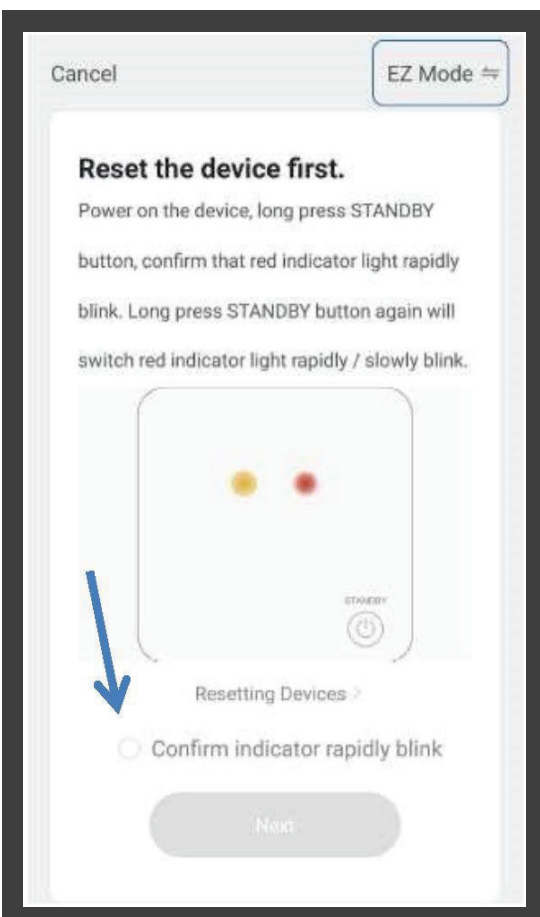

6. Establishing a connection

- ✔ Give a long press to the standby button for around 3 seconds.

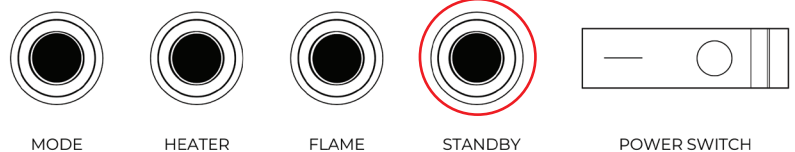

- ✔ You should see a red light next to the orange dot in the middle of the fire screen. The red light should be blinking quickly on the screen. Roughly 2 times per second.
- ✔ When prompted, if the red light is blinking rapidly, confirm that the indicator is rapidly blinking by checking the circle and then by pressing 'Next'

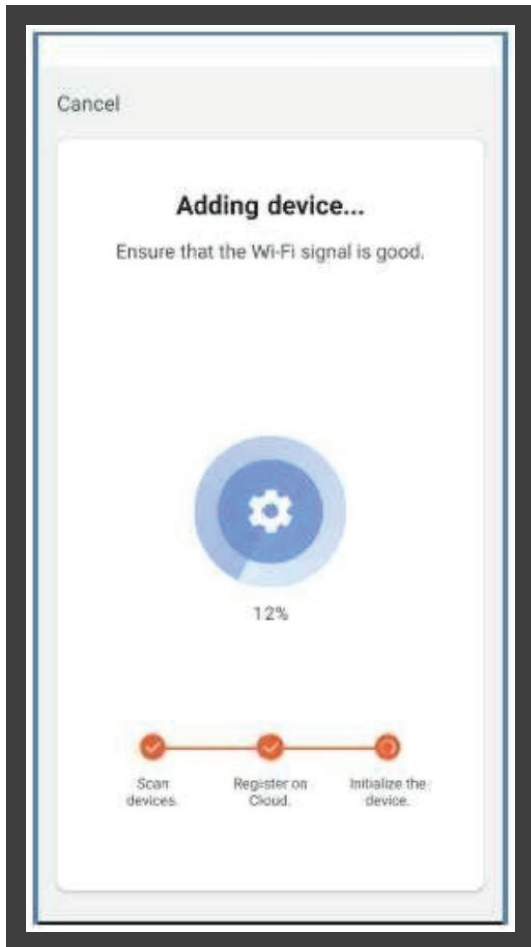

7. Adding your device

- ✔ Wait whilst the app adds the device. Please keep the phone close to the device whilst the device is syncing.
- ✔ If it fails to sync Repeat steps 4,5 and 6

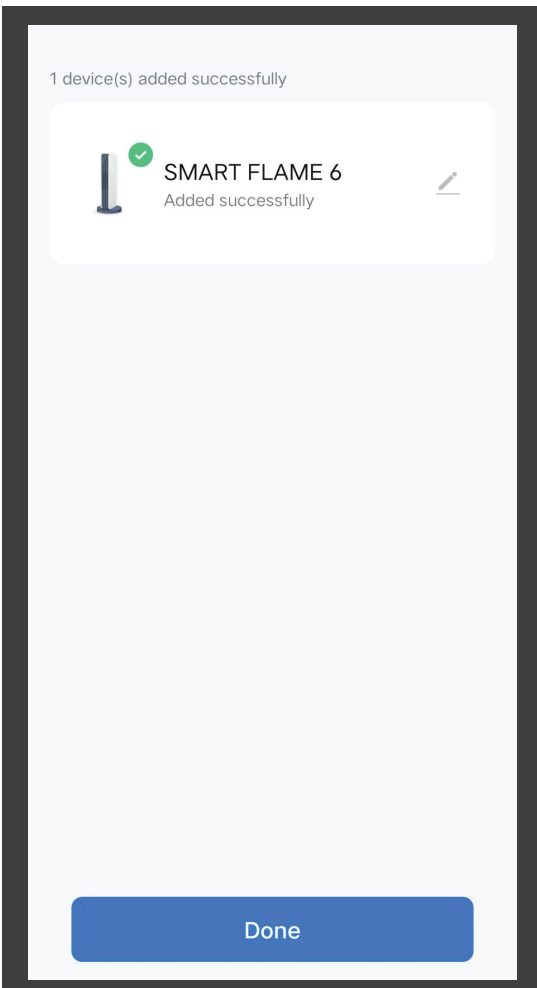

8. Your device has been added successfully.

Now your device has been successfully added click on the device and you are ready to start using your phone to control your fire.

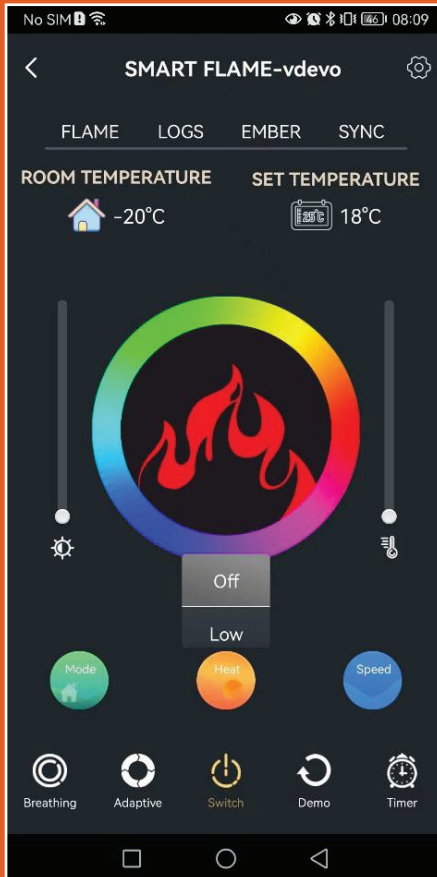
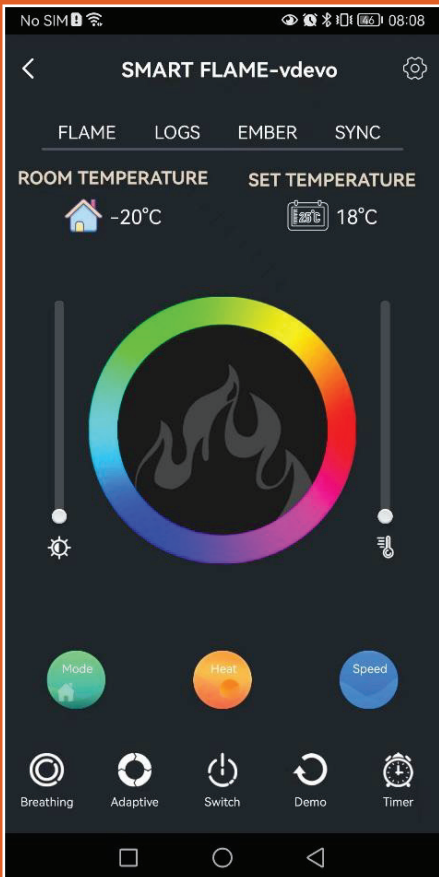

1. To turn the fire on press the Switch button at the bottom of the screen

2. To set timers press the clock button at the bottom right of the screen. 7 days timer is available on the APP

3. Popup buttons:

Mode- use this button to select preset colour mode.

Heat- use this button to select heat level.

Speed -use this button to select speed level

Along the top of the screen there are 4 tabs 'FLAME, LOGS, EMBER and SYNC'

Flame- use this tab to control the colours of the flames.

Logs- use this tab to control the colours of the Logs.

Ember-use this tab to control the colours of the embers.

Sync-use this tab to control the colours of all light.

For the flame, ember and logs settings you can turn the default Orange colour on/off by clicking the button and can add additional colours by pressing the colour wheel and then selecting your preferred colour from the big wheel above. Both the orange button and the colour wheel button can be pushed on and off.

Along the bottom of the screen, there are 5 buttons:

Breathing - use this button to switch breathing light on/off.

Adaptive - use this button to switch adaptive on/off.

Switch - use this button to switch the fire on/off.

Demo - use this button to switch demo on/off.

Timer - use this button to set weekly timer.



Maintenance:

You **MUST** remove the plug from the socket outlet and allow the heater to cool completely before cleaning or maintenance.

Cleaning:

A soft dry cloth, such as microfiber cloths, can be used to remove dust and for general day to day care.

If a more thorough clean is needed a damp cloth, NOT WET, may be used to wash the exterior surfaces. The glass can be cleaned with glass cleaner and a soft cloth.

The heater air flow vents must be hovered at least once per year.

WARNING

The appliance must fully dry before switching on.

Air Flow Vents



Heater

Safety Features

As this appliance contains a heating component there is an automatic thermal cut out safety feature. This feature stops the product from overheating and from potentially causing a fire.

If the appliance reaches a temperature above the guideline parameters the automatic thermal cut out safety feature will activate and the heater will cut out. However, the fans will continue to run in order to cool down the appliance.

Once sufficiently cooled the automatic thermal cut out safety feature will automatically reset and the heater will be restarted.

If this problem continues, turn off the fire and disconnect from the plug socket. Check that none of the ventilation vents are obstructed

CLEANING AND MAINTENANCE

Cleaning



ALWAYS turn the fireplace OFF and unplug the power cord from the outlet before cleaning, performing maintenance, or moving this fireplace. Failure to do so could result in electric shock, fire, or personal injury.



NEVER immerse in water or spray with water. Doing so could result in electric shock, fire, or personal injury. **NEVER** immerse in water or spray with water. Doing so could result in electric shock, fire, or personal injury.

Metal:

- ✓ Buff using a soft cloth, slightly dampened with a citrus oil-based product.
- ✓ DO NOT use brass polish or household cleaners as these products will damage the metal trim.

Glass:

- ✓ Use a good quality glass cleaner sprayed onto the cloth or towel. Dry thoroughly with a paper towel or lint-free cloth.
- ✓ **NEVER** use abrasive cleansers, liquid sprays, or any cleaner that could scratch the surface.

Vents:

- ✓ Use a vacuum or duster to remove dust and dirt from the fireplace and vent areas every 2 months.

Plastic:

- ✓ Wipe gently with a slightly damp cloth and a mild solution of dish soap and warm water.
- ✓ **NEVER** use abrasive cleansers, liquid sprays, or any cleaner that could scratch the surface.

Maintenance



Risk of electric shock! DO NOT OPEN any panels ! No user-serviceable parts inside!



ALWAYS turn the fireplace OFF and unplug the power cord from the outlet before cleaning, performing maintenance, or moving this fireplace. Failure to do so could result in electric shock, fire, or personal injury. **DO NOT OPEN any panels ! No user-serviceable parts inside!**

Electrical and Moving Parts:

- ✔ The fan motors are lubricated at the factory and will not require lubrication.
- ✔ Electrical components are integrated in the fireplace and are not serviceable by the consumer.

Storage:

- ✔ Store fireplace in a clean dry place when not in use.



WARNING! NO SERVICING of the internal or electrical parts should be performed by the consumer. Do not service the unit yourself.



Do not cut the plug off from the power cable doing this may result in your guarantee being void

NOTICE

When the fireplace is first turned on, a slight odor may be present. This is normal and should not occur again unless the fireplace is not used for a long period of time.

NOTICE

To improve operation, aim the remote control at the front of the fireplace. **DO NOT press the buttons too quickly.** Give the unit time to respond to each command.

Temperature Limiting Control

This heater is equipped with a Temperature Limiting Control. Should the heater reach an unsafe temperature, the heater will automatically turn OFF. To reset:

- 1 Unplug the power cord from the outlet.
- 2 Turn the ON/OFF switch on the CONTROL PANEL to OFF. Wait 5 minutes.
- 3 Inspect the fireplace to make sure no vents are blocked, or clogged with dust or lint. If they are, use a vacuum to clean the vent areas.
- 4 With the POWER switch in the OFF position, plug the power cord back into the outlet.
- 5 If the problem continues, have your outlet and wiring inspected by a professional.

Remote Control Battery Information

- ✔ This remote control uses two AAA **battery (not included)**.
- ✔ Instructions for battery installation are on the Remote Control battery compartment.



NEVER dispose of batteries in a fire. Failure to observe this precaution may result in an explosion. Dispose of batteries at your local hazardous material processing center.

TROUBLESHOOTING/ FAQ

<u>Problem</u>	<u>Possible Cause</u>	<u>Solution</u>	<u>Note</u>
Fire not turning on	Fire not plugged in or switched on at socket	Check plug is correctly fitted into socket and the socket is turned on.	If all solutions have been tested and problem persists, a new control panel is required.
	Fuse blown	Disconnect plug and inspect the fuse. Replace with a 13A fuse if broken.	
	Faulty control panel	If the controls do not work, press each control continuously one at a time. After a few cycles, the controls should recognize the input and work correctly.	
Noisy heater	Fan clogged	Remove the heating unit and remove dust from fan.	If all solutions have been tested and problem persists, a new heating element/ fan assembly is required.
	Fan unbalanced/ catching on housing	Manually re-center fan on each side. Check fan is not warped or damaged.	
Heater only blowing cold air	Fan clogged	Remove the heating unit and remove dust from fan.	If all solutions have been tested and problem persists, a new heating element/ fan assembly is required.
	Faulty heating element	Inspect the heating element and make sure all wires are firmly connected.	
	Faulty fan motor	Fan may be rotating too slow.	
No flame picture/ partial flame picture	Loose connection	Ensure all wires are connected firmly.	If all solutions have been tested and problem persists, a new PCB is most likely required.
	LED blown (If partial flame picture)	Test the faulty LED strip using another LED power connector that you know works. If LED strip still doesn't work, the fault is most likely with the LED strip and not the PCB. New LED strip required.	
	Damaged PCB	New PCB required.	

Heater cutting out	Build-up of hot air	Ensure inlets and outlet are free from obstruction and there are sufficient clearances surrounding the unit.	If problem persists, the installation will need assessed to ensure it adheres to all required minimum clearances as stated in this manual.
	Thermostat setting causing heater to cut-out	Adjust thermostat setting on remote to maintain desired room temp or deactivate thermostat setting.	
Heater switching on without activation	Thermostat set to keep room at certain temperature.	Adjust thermostat setting to maintain desired room temp or deactivate thermostat setting.	If all solutions have been tested and problem persists, a new PCB is required.
	Thermostat faulty	Replace PCB	

NOTE:

Wiring and exploded diagrams to assist with fire repair are available on request.

Product Warranty

Your Product is guaranteed for two years from the date of purchase.

Should this product prove defective within one year of purchase due to a design fault, workmanship or material breakdown, the product will be repaired or replaced free of charge. The Product warranty is subject to the following conditions:

- ✔ The product is to be used for domestic purposes only in accordance with the operating instructions.
- ✔ Responsibility of proof of purchase lies with the end user(s) who must prove product purchase within 12 month period of claim date.
- ✔ All warranties will be invalidated if unauthorized repairs or modifications are made to the electric fire, or in case of accident, misuse or damage caused by improper installation, or damage occurring during transit to or from the repairer.
- ✔ This warranty does not apply to heating elements, bulbs or fuses within this product
- ✔ Please inspect all products fully before installation we will not be held liable for product damages once the product has been installed.
- ✔ Products purchased from unauthorized sellers, including unauthorized websites, shall not be eligible for warranty benefits. (Unauthorized sellers) The warranty is only valid while the product remains with the original purchaser. If the Item is installed in another home and has a new ownership the warranty does not apply.

This warranty is none transferable.

Your rights under this guarantee are additional to your statutory rights, which in turn are not affected by this guarantee.

If your fire is to be built on to an existing chimney breast, the chimney must be blocked off as the drafts can affect the appliance causing it to over heat.

If the problem continues, keep the product unplugged from the power socket and contact your supplier.

 **WARNING!**

- ✔ The heater should **NEVER** be submerged in water.
- ✔ The interior should **NEVER** be wet.
- ✔ Cleaning chemicals such as but not limited to detergents, alcohols and abrasives should **NOT** be used.

Environment:

DO NOT throw out your appliance or its parts as municipal waste. Contact your local government for advice on the collection services and proper protocol in your area.

Please **DO NOT** dump your appliance as if not properly treated hazardous substances can leak into water supplies effecting animals and people's health and wellbeing.

If you are replacing your old appliance, retailers are legally obligated to dispose of your old appliance without any additional cost.



2-Year Limited Warranty:

You can register your product using the serial number above at www.evolutionfires.co.uk

Your product comes with a 24-month manufacturer guarantee, the guarantee covers the electrical firebox only, Woodwork is excluded from the guarantee. If you encounter any faults during the specified period, we suggest visiting our website and complete the report a fault page which can be found in the footer.

Please inspect and test all products before installation as we will not be held liable for product damages once the product has been installed.

Removal of the plug will invalidate your warranty.

Product warranty only applies if purchased through an Evolution Fires authorized seller only. The warranty is only valid while the product remains with the original purchaser. If the Item is installed in another home and has a new ownership the warranty does not apply.

For all warranty claims please visit our website, download the troubleshooting guide and follow the steps. If you need additional help submit a report a fault form which can be found in our website footer.

If you have purchased from one of our trade customers contact them for assistance.

Thank you for purchasing one of our products.

evolution  fires[®]

GET IN TOUCH



www.evolutionfires.co.uk



sales@evolutionfires.com



Unit 2 Firefly Square, Plantation Road, Burscough, Lancashire, L40 8JT
United Kingdom